

# INSTRUCTIONS AND REPAIR PARTS LIST

VP2  
Valve Series

**READ ALL DIRECTIONS CAREFULLY BEFORE BEGINNING INSTALLATION**

**Tools Required:** Teflon Tape, 1" Socket or Box End Wrench

**VP2 PARTS LIST**

Ref No	Item Number	Description	VP221	VP223	VP224	VP226	VP227	VP2-1/8RP	VP2-1/4RP
1	VP29	Valve Arm, Poly	•	•	•	•	•	•	•
2	VP21	Valve Body, Poly	•	•	•	•	•	•	•
3	VM106	Lock Pin, Poly	•	•	•	•	•	•	•
4	VP28	Plunger, Poly/Rubber	•	•	•	•	•	•	•
5	<b>VP24</b>	<b>1/8" Diameter Orifice, Poly</b>		•		•	•	•	
5	<b>VP26</b>	<b>1/4" Diameter Orifice, Poly</b>	•		•				•
6	VP112	5/8" O-Ring x .103, Rubber	•	•	•	•	•	•	•
7	<b>VP117</b>	<b>3/4" NPT Base, Brass</b>	•						
7	<b>VP118</b>	<b>1/2" NPT Base, Brass</b>				•			
7	<b>VP13</b>	<b>3/4" NPT Base, Poly</b>		•	•				
7	<b>VP14</b>	<b>1/2" NPT Base, Poly</b>					•		
8	VP15	Assembly Nut, Poly	•	•	•	•	•		

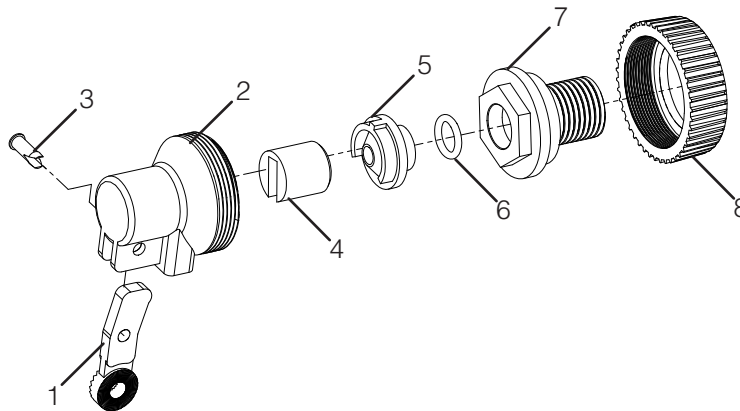

**MODEL NUMBERS**

The MODEL NUMBERS are: VP221, VP223, VP224, VP227, VP2-1/8RP, VP2-1/4RP

**WHEN ORDERING PARTS**

- (1) Show MODEL NUMBER and NAME: Example - VP221 Float Valve, 1/4" Orifice
- (2) Show PART NUMBER and FULL DESCRIPTION of part: Example - VP21 Valve Body, Poly

**HOW TO ORDER PARTS**

Repair parts may be ordered from your dealer.



PO BOX 2000 • HOUGHTON, IOWA 52631 • USA  
 PHONE: 319-469-4141 FAX: 319-469-4402  
 www.hawkeysteel.com E-MAIL: sales@hawkeysteel.com



ISHVP2  
 REV. 3.0  
 PRINTED IN U.S.A.

**VP2 Maximum Shut-Off Pressure (PSI) in Relation to Orifice Size and Float Arm Length**

	VP24 - 1/8" Orifice	VP26 - 1/4" Orifice
VA225P - 1-1/8" Arm	100 PSI	40 PSI
WC725P - 2-1/2" Arm	120 PSI	65 PSI
WC726P - 3-5/8" Arm	130 PSI	85 PSI

**STEP 1**

- Flush lines thoroughly to remove all foreign material.
- Do not subject valve to excessive tool pressures at any time.
- Hold inlet pipe securely while connecting to water supply line.
- Use Teflon tape or pipe seal on Base threads.
- Install Base, Assembly Nut and O-Ring first. Hand tighten Base plus one turn with 1" socket or box end wrench.

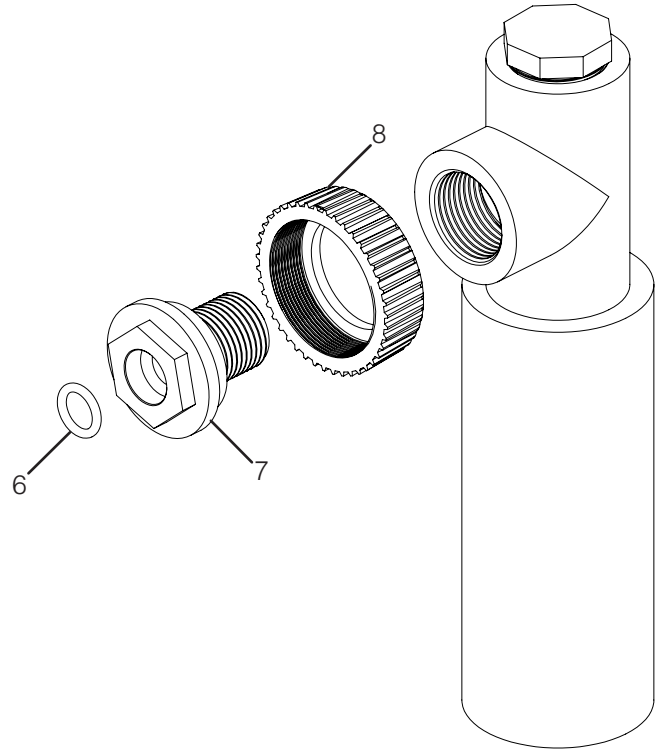

**STEP 2**

- First install Valve Arm in Valve Body using Lock Pin.
- Insert Plunger and Orifice in Valve Body.
- Thread Front Assembly onto Assembly Nut. Hand tighten only. Do not use Teflon tape on Valve Body.

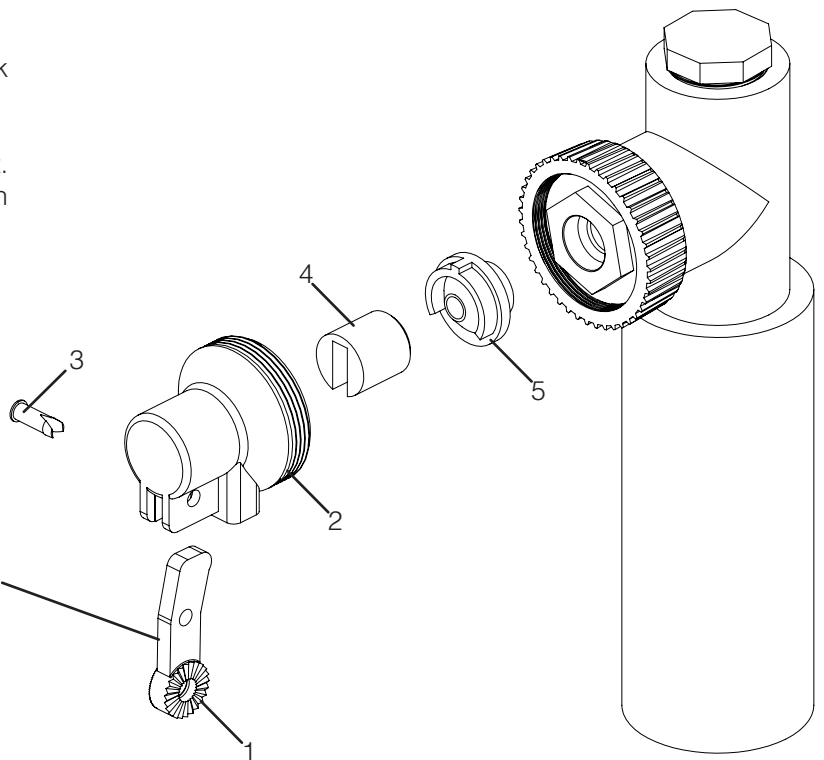

ATTENTION: DO NOT PUT PRESSURE ON VALVE ARM WHILE TIGHTENING FRONT VALVE ASSEMBLY.

# VP2 VALVE

- REPLACES VP1
- EASY TO CHANGE
- SIMPLICITY - FEWER PARTS
- INCREASED WATER FLOW

The fully assembled valve part numbers are VP221, VP223, VP224, VP226, VP227. The last 2 numbers on VP2 part nos. match up with our VP1 valve. If your drinker originally took a VP124, order a VP224, etc.

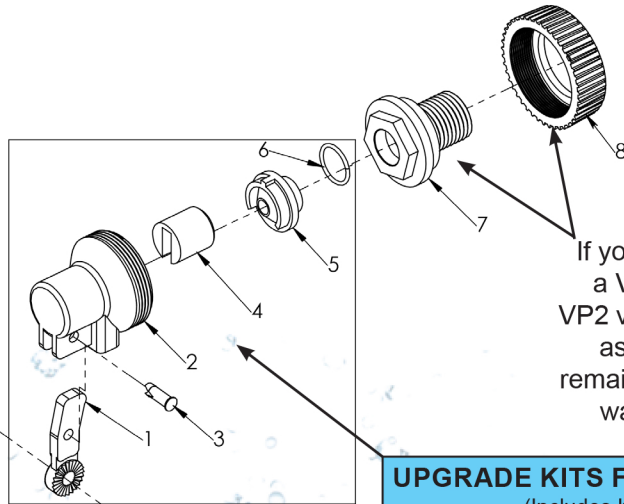

If you want to replace a VP1 valve with a VP2 valve, the base and assembly nut can remain connected to your water supply line.

### UPGRADE KITS FOR VP1 VALVES (Includes Items 1-6)

- VP2-1/8RP:**  
1/8 Inch Orifice  
(For Higher Pressures)
- VP2-1/4RP:**  
1/4 Inch Orifice

### VP224 VALVE VA6 FLOAT ARM VM117 FLOAT (Items 1-8)

Used on these models: WPM10, WPM10A, MPM10, MPM10A, WPM16, WPM20, MPM20, WPM80, WPM120, WPO25, MPO25, WPO50, & WPO70.

For: WPM14, WPO12, MPO12	For: WPO17, MPO17	For: MC, MJ, MK	For: MH
<p><b>VP223 Valve</b> <b>VA4 Float Arm</b> <b>VM117 Float</b></p>	<p><b>VP223 Valve</b> <b>VA225P Float Arm</b> <b>OP321 Float</b> (Float in Horizontal Position)</p>	<p><b>VP226 Valve</b> <b>VA225P Float Arm</b> <b>OP321 Float</b> (Float in Vertical Position)</p>	<p><b>VP221 Valve</b> <b>WC726P Float Arm</b> <b>OP321 Float</b> (Float in Vertical Position)</p>

### VP2 PARTS LIST

REF NO.	ITEM NO.	DESCRIPTION	VP221	VP223	VP224	VP226	VP227	VP2-1/8RP	VP2-1/4RP
1	VP29	Valve Arm, Poly	*	*	*	*	*	*	*
2	VP21	Valve Body, Poly	*	*	*	*	*	*	*
3	VM106	Lock Pin, Poly	*	*	*	*	*	*	*
4	VP28	Plunger, Poly/Rubber	*	*	*	*	*	*	*
5	VP24	1/8" Diameter Orifice, Poly		*		*	*	*	
5	VP26	1/4" Diameter Orifice, Poly	*		*				*
6	VP112	5/8" O-Ring x .103, Rubber	*	*	*	*	*	*	*
7	VP117	3/4" NPT Base, Brass	*						
7	VP118	1/2" NPT Base, Brass				*			
7	VP13	3/4" NPT Base, Poly		*	*				
7	VP14	1/2" NPT Base, Poly					*		
8	VP15	Assembly Nut, Poly	*	*	*	*	*		

### UPGRADE KITS FOR VP1 VALVES Include Items 1 - 6

- VP2-1/8RP:**  
1/8 Inch Orifice
- VP2-1/4RP:**  
1/4 Inch Orifice

Floats & Arms  
See Reverse Side

## FLOATS AND ARMS

Ref No	Item Number	Description	Ref	Item	Description
9	VP115	Adjust Screw, Poly	13	WC726P	Float Arm 3 5/8", Poly
10	VA6	Float Arm, 6", Poly	14	VM117	Float 4 3/8"(Diameter) x 2 7/8" Tall, Poly
11	VA4	Float Arm, 4", Poly	15	OP321	Float 3 1/2" x 4 1/2" x 3", Poly
12	VA225P	Float Arm, 1 1/8", Poly			

NEW!

### OP321 REDESIGNED FOR CENTER MOUNT & MORE BUOYANCY

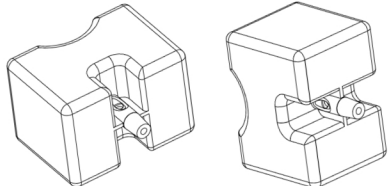

VP2 Maximum Shut-Off Pressure (PSI) in Relation to Orifice Size and Float Arm Length		
	VP24 - 1/8" Orifice	VP26 - 1/4" Orifice
VA225P - 1-1/8" Arm	100PSI	40 PSI
WC725P - 2-1/2" Arm	120 PSI	65 PSI
WC725P - 3-5/8" Arm	130 PSI	85 PSI
VA4 - 4" Arm	130 PSI	85 PSI
VA6 - 6" Arm	130 PSI	85 PSI

Valve Flow Rates					
Valve Number:	VP223	VP226	VP227	VP221	VP224
Orifice Number:	VP24—1/8"(.125)		VP26—1/4"(.250)		
PSI		Gallons Per Minute			
25		1.1		4.2	
40		1.3		7.5	
60		1.6		9.2	
80		1.9		9.7	

Orifices are interchangeable on all valves. We also have orifice part number VP25 which has a 3/32" diameter hole. It will flow about .5 to 1.5 gallons per minute. Flow rates are approximate.

## VP2 VALVE SERIES DESCRIPTIONS

Item Number	DESCRIPTION	UPC	Item Number	DESCRIPTION	UPC
VM106	Lock Pin, Poly		VP227	Valve, 1/2 Poly Base, 1/8 Orifice	
VM106-10	Lock Pin, Poly, Pk 10	0 85417 110 603	VP24	1/8 Orifice, Poly, VP2	
VP112	O-Ring 5/8 x .103, Rubber		VP24-10	1/8 Orifice, Poly, VP2, Pk 10	0 85417 15240 5
VP115	Adjust Screw, Poly, VP1/VP2		VP26	1/4 Orifice, Poly, VP2	
VP117	3/4 Valve Base, Brass, VP1/VP2		VP26-10	1/4 Orifice, Poly, VP2, Pk 10	0 85417 15260 3
VP118	1/2 Valve Base, Brass, VP1/VP2		VP28	Plunger, Poly, VP2	
VP13	3/4 Valve Base, Poly, VP1/VP2		VP28-10	Plunger, Poly, VP2, PK 10	0 85417 15280 2
VP14	1/2 Valve Base, Poly VP1/VP2		VP29	Valve Arm, Poly, VP2	
VP15	Assy Nut, Poly, VP1/VP2		VP29-10	Valve Arm, Poly, VP2, PK 10	0 85417 15290 0
VP21	Valve Body, Poly, Drilled, VP2		VA6	Float Arm, 6", Poly	
VP2-1/4RP	VP2 Front Valve Assy, 1/4 Orifice	0 85417 15147 7	VA4	Float Arm, 4", Poly	
VP2-1/8 RP	VP2 Front Valve Assy, 1/8 Orifice	0 85417 15187 3	VA225P	Float Arm, 1 1/8", Poly	
VP221	Valve, 3/4 Brass Base, 1/4 Orifice		VA225P-10	Float Arm, 1 1/8", PK 10	
VP223	Valve, 3/4 Poly Base, 1/8 Orifice		WC726P	Float Arm, 3 5/8", Poly	
VP224	Valve, 3/4 Poly Base, 1/4 Orifice		WC726P-10	Float Arm, 3 5/8", PK 10	
VP224K	Valve Pkg, 3/4 Poly Base, 1/4 Orifice	0 85417 15224 5	VM117	Float 4 3/8" x 2 7/8", Poly	
VP226	Valve, 1/2 Brass Base, 1/8 Orifice		OP321	Float, 3 1/2" x 4 1/2" x 3", Poly REDESIGNED	
VP226K	Valve Pkg, 1/2 Brass Base, 1/8 Orifice	0 85417 15226 9			



**EQUIPMENT & SYSTEMS FOR FEEDING AND WATERING ANIMALS**  
609 MAIN STREET PO BOX 2000 HOUGHTON, IA 52631 USA

DISTRIBUTED BY: